



The whole world of **SIEGENIA.**

The complete portfolio:
innovative hardware for windows and doors,
smart ventilation and building services.



Solutions inside. Solutions worldwide.

Integrated solutions for smart facades.

SIEGENIA offers an extensive and effective range of products that make up the key components of any smart building facade. This is where the full spectrum of innovative window, door and sliding door hardware meets the sophisticated solutions associated with ventilation and building technology. We are your single source of comprehensive and sophisticated system solutions that offer you numerous options to save time and costs in the production process.

As an experienced innovation leader, we know the market and the increasing demands of your clients. Our claim is to not only satisfy such demands, but to also exceed them and to set new standards. To this end, we ensure an optimal balance between convenience, security, styling and energy efficiency.

Achieving more together.

Innovation has always been a tradition with us – and it's been that way for four generations. In order to benefit consistently from market potential, we make extraordinary investments into research, development and process management and design innovative and trend-setting solutions in close cooperation with our partners. Turning a good solution into a first-class one requires daily practice.

Your competitive edge in the market is our motivation. This is why SIEGENIA is committed to providing ultimate quality and the highest level of customer satisfaction through individual service. Using tailor-made data systems technology, we create customised process solutions for efficient processes and support you throughout the entire process from planning to smooth implementation. We can also provide country-specific product solutions and will be happy to develop specifically adapted concepts.



The whole world of SIEGENIA:

- Window hardware
- Door hardware
- Sliding door hardware
- Ventilation technology
- Building technology



SIEGENIA worldwide:

- 6 Production sites
- 14 international sales and distribution locations

The complete
product range of
SIEGENIA.



Window hardware	06	Sliding door hardware	14
Window hardware, timber and PVC	07	Lift & slide fittings	15
Concealed hardware	10	Parallel tilt & slide fittings	16
Window hardware, aluminium	12	Parallel sliding fittings	17
		Fold & slide fittings	18
		Slide fittings	19

The framework for innovation.

Our trendsetting hardware solutions combine intelligent product details with numerous options for saving both time and costs during the production process.

SIEGENIA window hardware offers high functionality and security while providing the highest degree of design, convenience and quality. From manufacturing to installation, it maximises potential savings by reducing logistics and enabling lean workflows.

Making light work of heavy doors.

Expansive glazed areas add freedom, comfort and light to your interior. But they also increase the weight. To ensure that panoramic design does not make your windows difficult to operate, we develop extremely smooth running hardware – even for sliding elements weighing up to 400 kg. Thanks to our numerous innovations, design flexibility, convenience and security are no longer either-or criteria, they are the common denominator in our PORTAL sliding door solutions – from fabrication and assembly to operation.



Door hardware	20	Ventilation technology	28	Building technology	32
Multi-point locks	21	Window-mounted ventilators	29	Window monitoring systems	33
Electromechanical products	22	Wall-mounted ventilators	30	Motors for windows	34
Locks	23	Sensors	31	Motors for sliding systems	35
Emergency exit and panic door locks	24			Door monitoring systems	36
Frame parts	25				
Double-leaf doors	26				
Hinge side	27				

The key to secure doors.

Locking and resistance classes are not the only aspects of a door fitting. The feeling of safety and security is equally important, whether in your own four walls, at work or in public buildings.

This all-encompassing security concept results in a particularly extensive product portfolio including a complete range of multi-point locks for any requirement. KfV supplies modern locking systems of all kinds, from reliable mortise door locks to a versatile panic door lock system. Our experience and innovation allow us to combine maximum product quality with utmost efficiency and economy.

Clean air. Straight to your home.

Only controlled ventilation can create an all-round healthy indoor environment; one which combines home comfort, building protection and energy efficiency. Due to increasingly air-tight building shells, this requires a controlled exchange of air, automatically adjusted to the user's needs.

Our innovative window and wall-mounted ventilators supply fresh air both conveniently and efficiently. Our ventilators also recover valuable heat and protect against pollen, noise, mould and humidity. Other indoor air pollutants can be detected and regulated automatically by connecting intelligent air quality sensors.

Smarter living at the press of a button.

Modern living with a high quality of life is a question of the right system. The central component in this system is intelligently networked building technology in the form of motorised drives and locks, as well as intelligent monitoring systems.

Our trendsetting concepts open up new levels of home comfort and barrier-free access. This is supplemented by significant benefits in terms of security, energy efficiency and indoor environment. We also ensure that even complex systems are easy to operate.

At the end of the day, this not only increases quality of life, but also enhances the value of the property.





The hardware system for reduced installation time.

The TITAN AF system is suitable for windows made of timber, timber-aluminium and PVC. Almost all opening types such as rectangular, arched-head, rounded-head, and angled-head windows can be installed as single and double-sash windows.

The TITAN AF system makes use of all the benefits of the TITAN family, even for conventional hardware installation. Increased cost effectiveness and optimised logistics, tangible technical benefits and an attractive design can be achieved by using the same equipment. Since no additional measuring and cutting is required for resistance classes up to RC2, the manufacturing process speeds up considerably. An upgrade to RC3 is possible without any problems – for all permissible window sizes.

All the benefits at a glance:

- Reduced installation time thanks to numerous product improvements
- Sophisticated logistics to increase efficiency and profitability
- High-quality materials, efficient workability and high functionality
- Window elements available up to resistance class 3
- Simple assembly of hardware and window elements
- Surface-mounted or concealed hinge
- A good choice for home owners, too, thanks to the many practical benefits
- Custom designs possible due to a variety of products

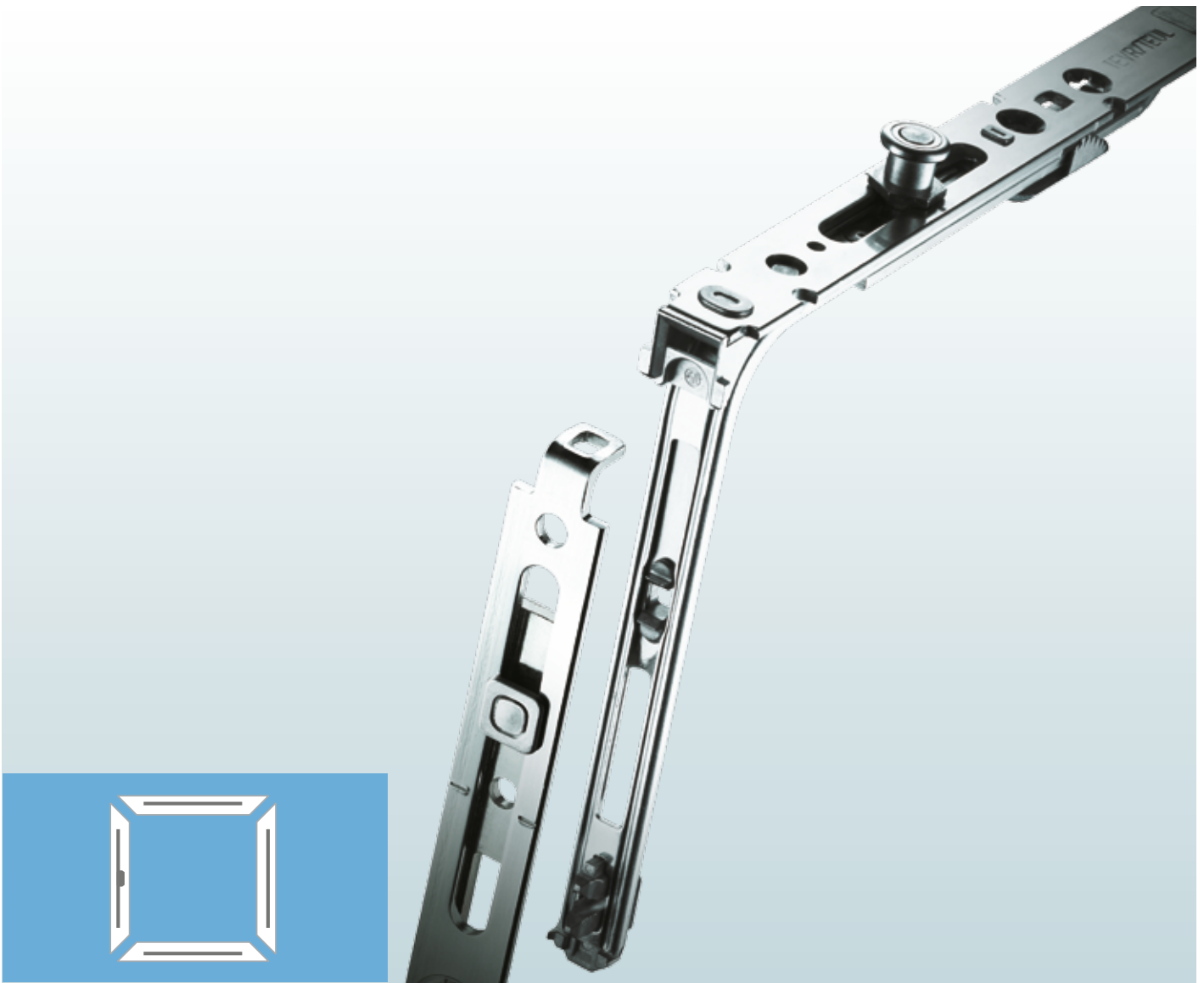

The hardware system for pre-weld manufacturing processes.

Optimised production chains require custom solutions, especially in window manufacturing with its ever increasing variety of types and shapes. The TITAN iP is a hardware system which allows assembly on frame and sash profiles before they are welded without demanding high investment costs. Its level of automation, which can be scaled as required, is the key to balanced cycle times, individual work processes and greater cost effectiveness in window manufacturing.

TITAN iP's functional versatility is another impressive feature. The hardware combines a high level of operating convenience with extraordinary durability and security. It is available for all frame materials and the various window and opening types.

All the benefits at a glance:

- Assembly on pre-weld sash profiles reduces cycle times up to 40 %
- Maximum length of components corresponds to euro pallet dimensions
- High-quality materials, efficient workability and high functionality
- Window elements available up to resistance class 3
- Simple assembly of hardware and window elements
- Surface-mounted or concealed hinge
- A good choice for home owners, too, thanks to the many practical benefits
- Custom designs possible due to a variety of products



The proven hardware classic.

The FAVORIT hardware system is the perfect all-round solution for all profile variants in timber, timber-aluminium, PVC and aluminium with 16 mm eurogroove. Continuously optimised over the years, it is characterised by its modular design and high internal system compatibility.

Thanks to its limited number of variants and its simple assembly technology, the FAVORIT system facilitates efficient manufacturing and warehousing as well as flexible, effortless installation. This simplifies the work of architectural hardware dealers and fabricators.

All the benefits at a glance:

- Numerous design options for designers and building contractors
- High quality certified to QM 328
- Extensive accessories to satisfy every requirement
- Attractive appearance, maximum corrosion resistance and hardware surfaces that have been coated using an environmentally-friendly process

axxent

Working perfectly undercover

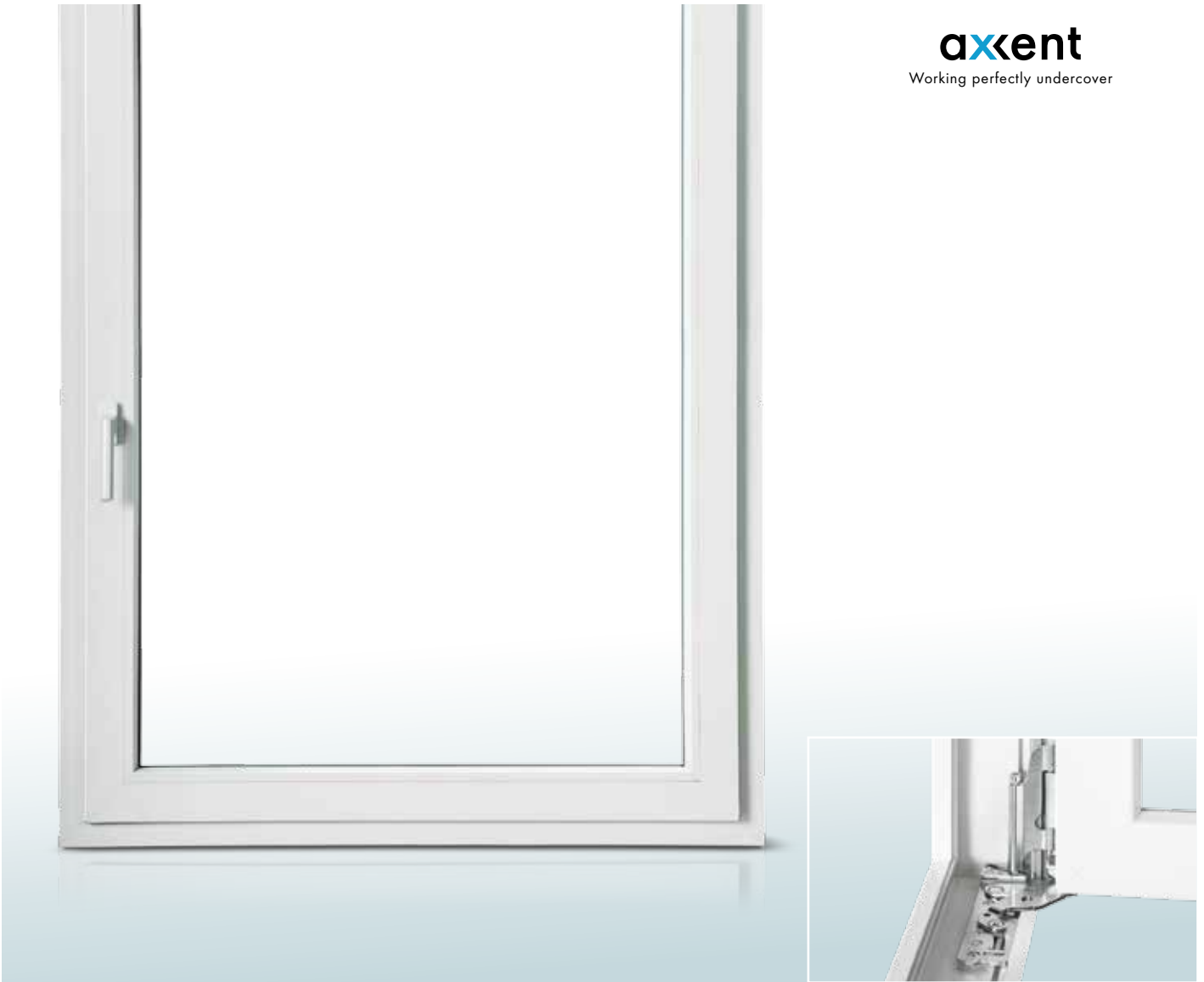

The new generation of concealed hardware.

With the axxent hardware range, we offer a new generation of concealed products that support the clear design and clean lines characteristic of modern architecture. In axxent, powerful design meets powerful technology.

Durability is not simply a promise with the TITAN axxent 34 system, but is its trademark. This concealed solution for rebate depths from 35 mm can handle even heavy sashes up to 160 kg with maximum load transfer and minimal wear. Its unique selling point is based on an innovative and durable support arm, which ensures optimal load transfer within the frame and perfect kinematics, even in the turn position. The system also provides many benefits in terms of installation.

All the benefits at a glance:

- Capacity of up to 130 kg for tilt & turn windows or up to 160 kg for side-hung windows without additional components
- Optimal load transfer with the frame thanks to the innovative supporting arm made of high tensile steel
- Hardened bottom hinge pin slides back and forth on two grooved pins with virtually no wear
- Perfect kinematics preserve the seals
- The bottom hinge is kept clean thanks to an attractive cover cap
- 95° opening width
- All the fabrication benefits of the TITAN AF or TITAN iP systems
- Simple installation of sash in turn or tilt position
- Easily accessible 3D adjustment
- Entire bottom hinge package is only 10 mm high:
Sash can be adjusted downwards by 2 mm



Undercover efficiency in a modular system.

The fully concealed ALU axxent hardware range allows you to offer architects attractive design options and clients elegantly styled windows while retaining all the benefits provided by our modular component system.

Enjoy optimised production processes thanks to the significantly reduced number of individual components and the high level of pre-assembly based on clamp-on compact components. The ALU axxent can be combined with the entire ALU system's universal range of accessories as required.

We can satisfy virtually all customer requests, from rose-free handles to anti-intruder windows up to RC2 with integrated electronic lock monitoring.

All the benefits at a glance:

- Capacity of up to 130 kg for tilt-only windows, tilt & turn and side-hung windows
- Concealed pivot points allow for narrow profile face widths
- Universal application in frame grooves from 10 to 14 mm
- Large opening angle of 110° in turn position
- Anti-slam device for the stay in the tilted position
- Quick assembly using clamp-on compact components



The truly universal hardware system.

Thanks to the pre-assembled component system, ALU 5200 products not only create window structures with a light, effortless appearance, but make installation easy. They require fewer parts and are quicker to install.

The ALU 2200 hardware has been specifically developed for smaller sash dimensions and sash weights up to 80 kg. Being a fully-fledged member of the ALU product family, it naturally offers all the benefits of the ALU series.

All the benefits at a glance:

- Pre-assembled component system for efficient assembly and warehousing
- Hardware can be used on the right or left as per DIN
- The central lock can be used vertically and horizontally
- Made of corrosion-resistant material
- Available in many RAL colours

ALU 5200 – up to sash weights of 150 kg

- The all-rounder in the family of ALU hardware products
- From standard applications to custom designs and ultimate operating conditions

ALU 5200 iP – up to sash weights of 150 kg

- Specifically developed for optimised production processes and optimal production logistics

ALU 2200 – up to sash weights of 80 kg

- The perfect entry into the complete ALU hardware range
- Suitable for integration into the modular ALU assembly system



Load-bearing hardware solutions for large-area glazing.

Expansive glass facades are the current trend, but also increase the weight of the structure. This is an exceptional challenge for the load-bearing capacity of the hardware but one which our designers were happy to tackle. The result is impressive: sash widths of up to 1100 mm, heights up to 2800 mm and permissible sash weights of up to 300 kg.

The ALU D300 is designed for side-hung sashes with weights of up to 300 kg. The ALU DK200 is designed for tilt & turn windows with weights of up to 200 kg. Both feature highly flexible adjustment options and an extensive range of accessories.

All the benefits at a glance:

- Product-compatible modular system ensures efficient logistics
- Comprehensive range of accessories
- Ideally suited for sound-proofing, thermal insulation and anti-intruder protection

ALU D300 – for sash weights of up to 300 kg

- “Turn” opening variant
- Infinitely adjustable height
- Also available as barrier-free version to DIN 18040

ALU DK200 – for sash weights of up to 200 kg

- Tilt & turn opening variants
- Infinite height and width adjustment

Sliding door hardware for
timber, PVC and aluminium:
Lift & slide
Parallel slide
Parallel tilt & slide
Fold & slide





The lift & slide hardware with a barrier-free threshold.

Our particularly smooth operating PORTAL sliding door systems prove day after day how heavy weights can be moved easily. The systems are not based on a one-size-fits-all approach, but deliver an uncompromised blend of design freedom, convenience and security for all weight classes.

Decades of development expertise have made SIEGENIA lift & slide technology so sophisticated that even a sash weighing up to 400 kg can be operated safely, conveniently, and effortlessly. When used with timber, PVC or aluminium, the PORTAL HS system provides opening widths of up to 12 m with a barrier-free threshold while far exceeding minimum thermal insulation requirements.

All the benefits at a glance:

- Suitable for timber thicknesses up to IV 92
- Night vent as standard
- Standard hardware already features basic security level, easy to upgrade to RC2 as per EN 1627-1630
- A large range of handle colours allow for a variety of design options: white, brown, silver, nickel silver, light matt titanium and medium bronze
- Handles can be painted in any colour retrospectively, as required

The new ECO PASS threshold – a completely new design:

- 10-chamber design allows for optimal heat insulation
- Absolutely barrier-free thanks to step plates which can be retrofitted in accordance with DIN 18040
- Stable, single-part solution with individual design options



The parallel tilt & slide (PSK) hardware for versatile convenience and security.

Architects want more variety and greater design flexibility, whilst clients demand more light and convenience. The parallel slide & tilt elements of the PSK^{PLUS} hardware provide solutions that satisfy both. The PLUS stands for a wealth of improvements, which further enhance the PSK range that has already proven itself in the market-place.

Even the basic versions of the PSK^{PLUS} fittings provide security and intruder protection thanks to their comfort mushroom cams in all four corners that prevent the door from being levered open. Using additional comfort mushroom cams and striker plates made of hardened steel, the level of security can be continuously increased.

PORTAL PSK^{PLUS}:

- PSK 100^{PLUS}, PSK 130^{PLUS} and PSK 160^{PLUS} for small and medium-sized sashes weighing up to 100, 130 or 160 kg
- PSK 200-Z^{PLUS} with handle control for large and heavy sashes weighing up to 200 kg
- Comfort mushroom cams throughout the system add security, up to level RC2 is possible
- A frame-to-sash clearance of 125 mm also makes it suitable for elements with large profile thicknesses
- Running track requires only 35 mm
- For profiles with a 16 mm fitting groove in all frame materials

PORTAL PSK 160^{PLUS} ALU:

- For sash weights up to 160 kg
- For aluminium profiles with 21 mm cavity
- Frame-to-sash clearance of up to 118 mm makes the hardware suitable for use with elements with large profile thicknesses
- Available in white, brown, and silver



The parallel sliding hardware with dual stay control.

With the PORTAL PS^{PLUS}, a simple 90° turn of the handle is enough to open even heavy, large sliding elements without virtually any effort. An important technical detail of the new hardware is the dual assisted stay control. The previously complex opening process, which involved the manual effort of bringing the sash into the tilt and slide position, has been simplified considerably. The solution: the bogies and dual stays move the sash out of the frame simultaneously. It is the only one of its kind on the market. In addition, the hardware shares all of the same advantages of the trusted PSK 200-Z^{PLUS}.

All the benefits at a glance:

- Comfort mushroom cams throughout the system add security, up to level RC2 is possible
- All the benefits of the PSK 200-Z^{PLUS}
- Easy operation: a solution for buildings with frequently changing user groups, e.g. hotels and offices
- The number of required components has been reduced to the minimum to facilitate familiarisation with the products and lower warehousing costs



The fold & slide fitting for large openings and full flexibility.

The PORTAL FS^{PLUS} enables up to seven fold & slide elements, weighing up to 80 kg per sash, to be effortlessly folded together, thereby creating opening widths of up to 6.3 metres. The hardware covers can be painted in any colour to suit any design.

Fold & slide elements that open outwards also open up new areas of business. The use of new materials and coating technologies make the new hardware ideal for long-term use outdoors as well.

PORTAL FS^{PLUS}:

- Top or bottom running
- Inward or outward opening
- Smooth sash motion thanks to ball-bearing rollers made of special PVC
- Plastic bearing makes the sash hinges maintenance-free
- Also available in a highly corrosion-resistant stainless steel look
- Barrier-free threshold versions in accordance with DIN 18040 are available
- For profiles with 16-mm fitting groove in all frame materials

PORTAL FS^{PLUS} ALU:

- Top or bottom running with the same profile set
- For profiles with ALU eurogroove
- Stable running track with convenient threshold height
- Smooth running
- Efficient installation thanks to few, ready-to-assemble components



The new sliding hardware with the special sealing system.

The special sealing system of the ECO SLIDE fitting from SIEGENIA is what sets it apart from the competition. This completely newly developed product from the PORTAL product group combines the simple operation of lift & slide systems with the superior weather tightness of tilt & slide mechanisms. All this is made possible through its unique design, which combines a continuous, all-round seal with special bogie wheels and innovative guiding and locking elements.

A total of four of these elements guide the sash precisely into its final locked position. The force required to create the seal is transferred from the handle through the gear and finally to the two locking hooks. These locking hooks then generate the approximately 15 mm closing or opening movement of the sash while special plastic stops absorb the impact noise. The 16-mm gear fitting groove is identical to the standard groove used in tilt & turn windows so no modifications are necessary.

All the benefits at a glance:

- Highly waterproof thanks to continuous, all-round seal
- Night vent as standard
- Easy to operate
- Barrier-free solutions available
- Narrow face widths available
- Quick and simple installation
- Low-maintenance

KFV

Multi-point locks
Electromechanical products
Locks
Emergency exit and panic door locks
Frame parts
Double-leaf doors
Hinge





Wide range of variants with variable pocket positions: Standardised milled surfaces and reduced warehousing.

By choosing the top range of multi-point locks available, you are opting for clever variable pocket positions in timber, PVC or aluminium doors, consistent milled surfaces and mutually compatible product families – all from a single supplier. Our perfectly standardised modular system concept enables you to achieve even more effective results with our hugely diverse range of solutions and also offers significant assembly, warehousing and installation benefits.

Automatic multi-point lock AS 3500:

Contactless magnetic system for ultimate locking convenience.

Two solid hookbolts lock by contact-free magnet technology alone, without any additional release catches. This creates a reassuring sound when closing without latch contact and a unique flush appearance. The patented magnetic trigger compensates for airgap tolerance automatically. The hooks extend 20 mm and lock upwards and downwards. They are locked into the end position using back pressure. This ensures that the lock functions properly even if the door is warped.



Key-operated

Locking and unlocking via double-turn of key.



Lever-operated

Locking and unlocking from inside using handle, key can be used for deadlock.



Service lock

Flexible system for instant assistance when repairing faulty doors, irrespective of manufacturer.



Convenience and security at the push of a button.

The GENIUS mechatronic locking and unlocking system combines the locking properties of a mechatronic multi-point lock with the convenient features of state-of-the-art electronics. Depending on the version, it is suitable for use in private homes and in commercial or industrial buildings. GENIUS can be combined with numerous access control systems and many other applications, making a multitude of custom solutions possible.

All the benefits at a glance:

- Electronic locking and unlocking of all locking bolts
- Permanent lock monitoring
- Optimal seal
- Low installation width of only 16 mm and a minimum installation depth of 52 mm
- Profile cylinder makes mechanical operation possible at any time
- Toggle switch in the face plate for day and night switching
- Can be combined with external access control systems
- Permanent standby state without cool-down phases

GENIUS EA:

- With integrated control electronics and electronically controlled gear motor
- Can be combined with external access control systems or the KfV radio or transponder system

GENIUS EB:

- As an additional feature compared to Version EA, this system can also be combined with external systems such as time switches, swing door drives, or alarm systems
- With integrated control electronics for connecting the KfV fingerprint identification or KfV IR access control

GENIUS CA/CB:

- As an additional feature as compared to versions EA and EB, this one comes with a "Comfort" quick-release mechanism that instantly releases the latch when operating the inside handle.



Logical solutions for timber and metal doors in all requirement classes.

Our wide range of locks manufactured to ultimate quality standards and for any application offers a matching DIN or custom solution in accordance with usage frequency and security requirements.

Doors for private homes or public buildings, as original or retrofitted equipment: our high-quality KFV mortise door locks for rebated and non-rebated doors are a perfect match. They are available for lever locks, bathroom door knobs or cylinders. The product range is supplemented by a large variety of tubular frame and special locks.

Magnetic locks:

Where visual appeal and ultimate locking convenience go hand in hand.

In these locks, the latches are released by special magnets integrated in the frame part and in the actual latch. When the door is open, the latch is in line with the lock face plate, and therefore virtually invisible. The latch only extends into the frame part and is secured in place by magnetic force when the door is fully closed. Perfect design is combined with a noise-dampened and smooth closing operation as the latch does not touch the frame profile.



Mortise door locks
according to DIN 18251
in classes 1 to 4.



Locks for tubular frames
Single- or double-turn,
with various bolt throws
and backsets.



Special locks
for steel, moisture-proof and radiation
protection doors as well as for sliding,
glass and double-action doors.



Reliable and efficient solutions in accordance with EN 179 and EN 1125.

Whether it's an emergency exit or panic door lock, whether it's a mortise door lock, tube frame lock or multi-point lock: the proven solutions of the KfV panic product range always combine ultimate functional reliability and intruder protection with simple operation and innovative and efficient product details.

With our mortise locks, tube frame locks and multi-point locks, escape and DIN direction can be set simply by adjusting the latch. Accordingly, you only need one product for all escape and opening directions.

The escape door functions of our multi-point locks for single and double-sash doors are based on the same main lock families and all additional locks have identical dimensions.

All the benefits at a glance:

- Direction of escape can be set on the main lock for function B and D
- Suitable for fire-rated doors (minimum face plate widths of 16 mm)
- Adjustable DIN direction
- Escutcheon holes at a minimum 35 mm backset
- Compatible with KfV standard frame parts
- DIN cylinder with and without free-swinging function or round cylinder can be used
- Simple assembly of the double leaf solution by omitting long threaded rods

The locking functions:

Our escape door solutions can generally be opened in the direction of escape without a key, even when locked. The options for opening against the direction of escape depend on the locking function (switching function B, passage function D or cylinder-operated lock E).



The versatile frame range for multiple profile systems.

The cost effectiveness and versatility of our range of frame parts is not based on the multitude of different frame part variants. On the contrary! Due to its clever pocket positions, identical milled surfaces and thanks to the unique Q adjustment, no special frame parts are required, which contributes to efficient lean warehousing and flexible assembly.

The frame parts with Q adjustment can be used with all types of multi-point locks with bolts, hooks (6 mm / 8 mm) or a combination of bolts and hooks. Another benefit: tolerances can be compensated for by the adjustment range of 5 mm, which is the largest of any complete product range in the market. Also, these frame parts feature a very low installation depth and a high visual appeal.

Applications for frame parts with Q adjustment:

- Key- or handle-operated multi-point locks
- Automatic multi-point locks
- Three-latch multi-point locks
- Panic multi-point locks

The designs:

- Single locking panels and locking rails for different door heights
- Available with and without latch slide technology
- Frame parts for door security locks
- Surfaces: galvanised, powder-coated and stainless steel

Upgrade options:

- Daytime latch: main lock latch is released by a mechanical catch which is easily switched at the manual locking slider
- Hinge-side security device: optimal protection of the door against being levered open thanks to two wedge lock elements with interlocking splines



Convenient and efficient solutions for inactive leaves.

In addition to the proven standard shootbolt solutions, KfV has a comprehensive range of keep bolts for double leaf doors made of aluminium, timber and PVC. These hardware solutions provide an extraordinary security level thanks to their strong vertical deadbolts. They can be combined with mechanical and electronic multi-point locks.

In addition to their smooth operation and their attractive styling, these hinges are characterized by their intelligent modular design. Extraordinary flexibility and quick installation as well as lean warehousing are the benefits. The new BS80 keep bolt leads the way.

All the benefits at a glance:

- SKG-tested
- Smooth operation
- Time-saving assembly
- Thick bolts makes it particularly secure
- With deadbolts that extend 20 mm upwards and downwards to lock
- For door heights from 2010 mm to 3155 mm
- NEW: BS80 keep bolt with convenient T control lever

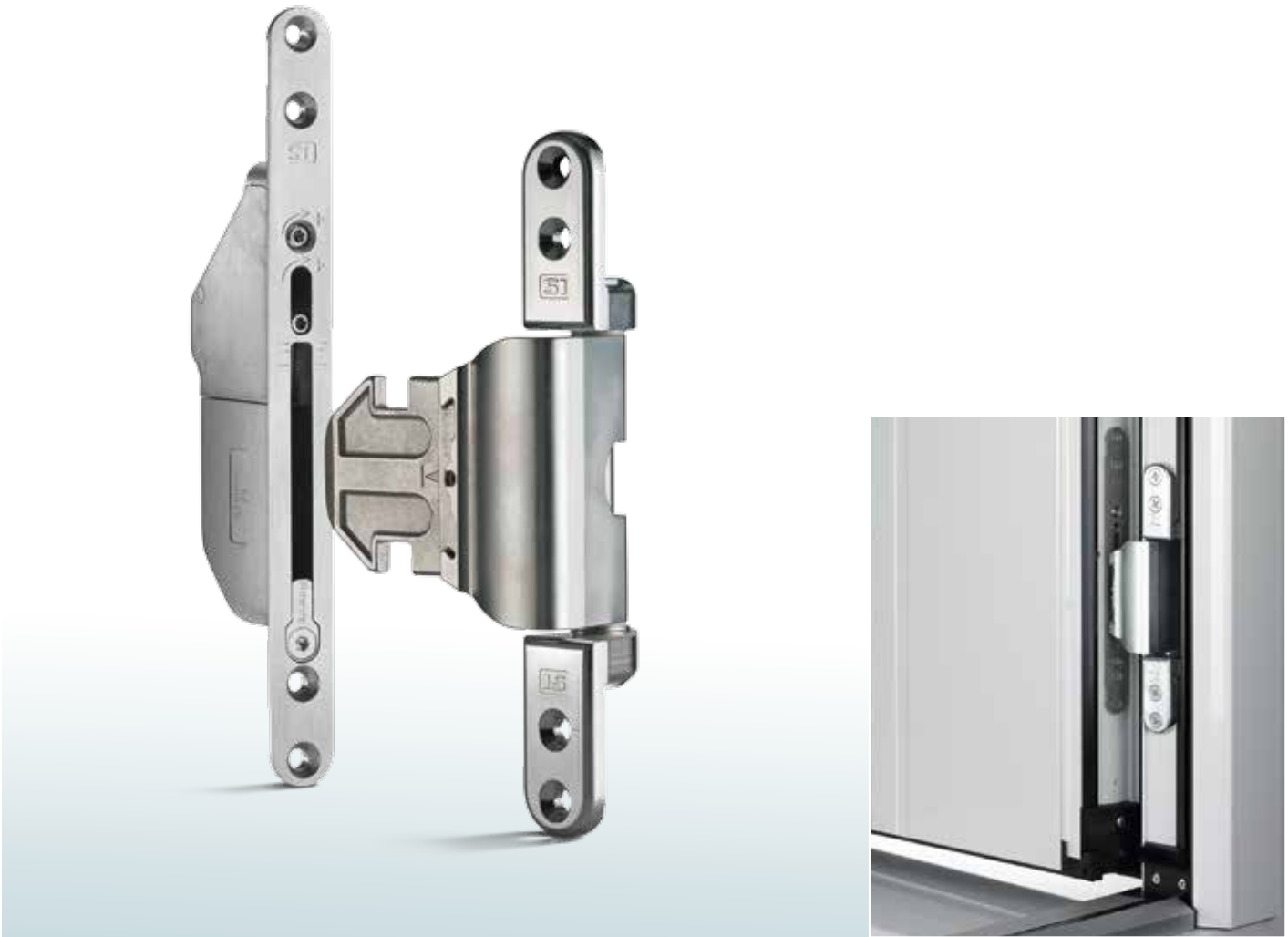

Security by design.

Durable and reliable hardware makes for secure doors. Easy and flexible installation creates a high level of efficiency. And a fully concealed hinge turns doors into discreet design elements complementing any elegant interior. To combine robustness, cost-effectiveness and styling into one piece of hardware, we have developed the axxent door hinge specifically for aluminium doors.

The two-piece hinge with frame and sash part is designed for sash weights of up to 120 kg. It requires only minor profile milling and offers many benefits in terms of installation: to connect the sash, simply push it in and then use the convenient 3D adjustment mechanism providing maximum scope for lateral, height and compression adjustment.

All the benefits at a glance:

- Two-piece hinge with frame and sash part for aluminium doors
- Easy removal and installation of sash
- Simple 3D adjustment and large adjustment range
- Durable technology, load bearing capacity for door weights of up to 120 kg
- Low profile milling required



For precise and flexible implementation, even of unusual projects.

SIEGENIA offers an extensive range of innovative ventilation units for installation in or around windows. Whether integrated and virtually invisible or intended to catch the eye, whether motor-driven active ventilators or passive ventilators reliant on natural pressure differential, our ventilation systems are more than just powerful. They are exceptionally versatile and flexible, thanks to their modular design. Individual and customised ventilation concepts can be realised, even for highly demanding projects.

AEROMAT VT with heat recovery:

Flexible installation, efficient ventilation.

The compact AEROMAT VT window ventilator with heat recovery combines energy efficiency with humidity control and a healthy indoor environment to the greatest possible effect. In addition to its thermal efficiency of up to 62 %, the ventilator provides first-class air throughput as well as extraordinary sound absorption, including intelligent filter technology which protects against fine dust and pollen. For ultimate flexibility, it can be integrated vertically into the facade, also making it practically invisible.



AEROMAT intense

The flexible, passive sound absorbing ventilator with self-adjusting volumetric flow flap.



AEROMAT 80/100/150

The variable window ventilator for excellent noise insulation.



AEROMAT midi

The smart passive ventilator with double locking mechanism and volumetric flow flap.



AEROMAT mini

Window rebate ventilator with optional turn lock.



Flexible solutions for retrofitting.

There is a lot to be said for using high performance wall-mounted ventilators, particularly in renovations. Thanks to their easy and quick installation, they can also be integrated flexibly into building plans at a later stage.

Depending on the type of ventilator, wall-mounted ventilators offer many additional functions to enhance the quality of life such as optimal sound absorption and heat recovery or integrated protection against humidity and highly effective filter technology. Furthermore, they are very easy to operate and maintain.

AEROPAC®:

The small sound-absorbing ventilator with big benefits.

Compact, silent and already proven thousands of times over: our sound-absorbing ventilator AEROPAC® is the answer to the increased noise pollution from the fresh air supply in many places. In combination with sound insulated windows, the AEROPAC's sound absorption turns your four walls once again into a place of quietness and relaxation, regardless of road, rail or air traffic outside. Thanks to three different optional filters, other environmental problems such as fine dust and pollen stay outside too.



AEROVITAL®

The universal ventilator with pollen protection, heat recovery and total convenience.



AEROLIFE®

The energy-saving universal ventilator with pollen protection and heat recovery.



AEROPLUS®

The pro for indoor climate control and dehumidification.



The intelligent air quality sensor for activating window and wall-mounted ventilators.

SENSOAIR gives you the green light for clean air and a healthy sense of well-being with full productivity. The smart air quality sensor detects many different types of pollution in the room air – before the human body can even react and the recommended values are exceeded. By automatically activating wall-mounted or window-mounted ventilators as needed, the SENSOAIR combats CO₂, nicotine, smoke and unpleasant odours. The ventilation traffic lights integrated into the casing allow you to check the current air conditions in the room.

Installation and functionality form a smart combination: the SENSOAIR can be connected quickly and easily either by conventional hard-wiring or via the Z-Wave wireless connection.

All the benefits at a glance:

- Recognises many different pollutants in the room air
- Facilitates energy-efficient, demand-based ventilation
- Elegant design, trouble-free installation
- Can be used anywhere with conventional wiring or via a wireless Z-Wave connection

Variants:

- SENSOAIR basic table unit
- SENSOAIR plus for controlling ventilation equipment and motorised drives
- SENSOAIR wave for integration in Z-Wave wireless systems





App-based window security system: simple, secure, smart.

For a security specialist, the first step in securing a window is to ensure that it meets resistance class 1. For a user, on the other hand, the first step is to shut the window. Because when windows are left open, even the most state-of-the-art security fittings count for nothing. To make sure users benefit every time from our conventional intruder resistance fittings, SIEGENIA-AUBI Sicherheits-Service GmbH now offers the iWindow electronic control and monitoring system.

This user-friendly, app-based solution can be quickly and easily retrofitted on almost all SIEGENIA hardware. It lets you keep an eye on all your windows at once, simultaneously opening up whole new possibilities for managing comfort in your home. Because iWindow can be used to network all devices of the electronic home and entertainment systems – irrespective of manufacturer – via your smartphone, pad or tablet PC, effectively turning your mobile device into a universal remote control.

All the benefits at a glance:

- Reliable monitoring of the state of windows and doors
- User-friendly app-solution comprising only a few elements:
 - One transmitter and one magnetic clip per window or door
 - SIEGENIA gateway for wireless network integration
 - Software for independent set-up by user
- Allows network integration and control of all consumer electronics irrespective of manufacturer
- Can be retrofitted quickly and simply on almost all SIEGENIA hardware



Powerful motors for more quality of life.

Our motor drive and locking solutions are designed for easy operation with the aim of making daily life more convenient. In addition, secure and barrier-free living, the option of user independent ventilation and concealed hardware always add value to any property, whether it's a residential building, a school, retirement home or office building.

The compact and powerful units are easy to install, integrate perfectly into building technology and blend into any type of architecture and facade.

DRIVE axxent DK:

Concealed chain drive with locking function.

The easy-to-install chain drive features first-class design and is fully concealed in the frame profile of tilt & turn windows made of timber, PVC or aluminium. It enables fully automated, controlled window ventilation, always providing a breath of fresh air in high-quality residential and commercial buildings. The DRIVE axxent DK is easily controlled by push buttons, wireless connection or infrared remote control or by iWindow.



DRIVE axxent

Concealed chain drive with 350 mm opening width.



Motorised handle MH10

Convenient opening and closing at the touch of a button.



Barrier-free drive solutions for slide systems and lift & slide systems.

To ensure unlimited home comfort even when handling 400 kg single- or double-sash large windows, SIEGENIA now offers motorised drive systems. These systems open or close the locking parts on the sashes automatically and move the sashes into the open and closed position. The desired position can be set either by using an integrated button in the motorised handle or by using the convenient remote control.

The MHS400 drive for lift & slide systems (system A and C) and the MSA400 drive for slide systems are also perfectly suitable for retrofitting as they are not dependent on the make of hardware and profiles. In conjunction with the low ECO PASS threshold, both system can be used to create a barrier-free passage.

All the benefits at a glance:

- Automatic sash movement, including automatic locking and unlocking with MHS
- Suitable for sash weight up to 400 kg
- Automatic programming, programmable opening width, timer facility
- MHS: Night vent secured with locking bolts
- With infrared remote control and wall bracket
- Suitable for retrofitting to almost any profile type and system, independent of the hardware manufacturer
- Quick installation without any profile milling: Pre-assembled drive and plug & play design
- Anti-pinch protection: Complete safety in accordance with DIN 18650-1 and -2 and DIN EN 60335-1, MHS also with internationally recognised CB certification
- Operable by wheelchair users and compliant with DIN 18025 if used in conjunction with flat threshold



The app solution for secure doors: Look, no hands.

The market for keyless smart access control systems is growing. However, only the KFVkeyless electronic control system as a user-friendly app provides a solution that combines convenient and secure operation with straightforward and clear access rights control.

The system allows mobile devices to be used in two ways: for automatic door opening via the Bluetooth function of the authorised standard mobile phone or, alternatively, via code input using the keypad. Registered mobile phones and door codes can be managed easily via a high-end mobile device or smartpad.

All the benefits at a glance:

- Safe electronic access control system to support mechanical intruder protection
- App solution comprising:
 - KFVkeyless App for iPhone, iPad or Android (available at App Store or Android market)
 - KFVkeyless access control system: Bluetooth receiver with additional keypad and relay cable
- Contactless opening of doors via Bluetooth function of mobile phone – or, alternatively, by entering a code into the keypad
- Management of access rights for up to 45 Bluetooth devices using an app via a smartphone or smartpad
- Compatible with KFV multi-point locks GENIUS type A and B as well as AS 3500 with automated latch release type A and F

More products. More Topics.
More service.

Up-to-date information about the entire product range is available to download from the SIEGENIA website.

Further online media:
www.axxent-beschlag.de
www.iwindow.de
www.upgrade-your-business.info
werkbank.siegenia.com

www.siegenia.com



Product brochure
TITAN



Product brochure
Aluminium



Product brochure
Sliding door
hardware



Product brochure
Door hardware

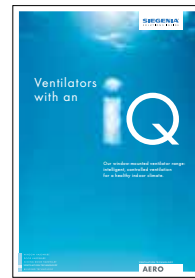

Product brochure
Window ventilators

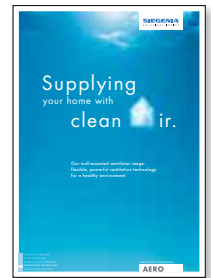

Product brochure
Wall-mounted
ventilators

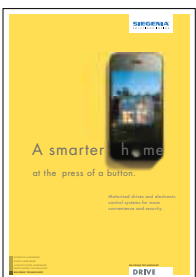

Product brochure
Building technology

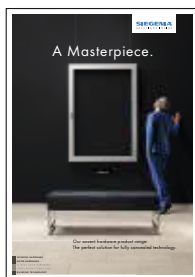

Theme brochure
axxent



Germany



SIEGENIA-AUBI KG

Headquarters / TITAN plant
Industriestraße 1-3
57234 Wilnsdorf
Phone: +49 271 3931-0
Fax: +49 271 3931-333

PORTAL plant
Am Fohlgarten 6
54411 Hermeskeil
Phone: +49 6503 917-0
Fax: +49 6503 917-100

ALU / AERO / DRIVE plant
Duisburger Straße 8
57234 Wilnsdorf
Phone: +49 271 3931-0
Fax: +49 271 3931-333

SIEGENIA-AUBI Sicherheits-Service GmbH
Am Weiher
54421 Reinsfeld
Phone: +49 6503 917-430
Fax: +49 6503 917-425

KFV Karl Fliether GmbH & Co. KG
Siemensstraße 10
42551 Velbert
Phone: +49 2051 278-0
Fax: +49 2051 278-167

info@siegenia.com

Austria



SIEGENIA GROUP

Austria sales office
Salzburger Straße 18
5301 Eugendorf, Austria
Phone: +43 6225 8301
Fax: +43 6225 8301114

info-a@siegenia.com

Belarus



SIEGENIA GROUP

Representative office Belarus
P. Glebki Str. 11/1 Room 215
220104 Minsk
Phone: + 375 17 3121168
Fax: + 375 17 3121168

info-by@siegenia.com

Benelux



SIEGENIA GROUP

Benelux sales office
Derbystraat 49
9051 Sint-Denijs-Westrem
Phone: +32 9 2811312
Fax: +32 9 2828023

info-b@siegenia.com

China



SANHE SIEGENIA-AUBI

Hardware for Windows and Doors Ltd.

Northeast of Jing-Long Industrial Park
No. 3, Yan-Xin Street, Yanjiao, Langfang,
Hebei Province, P. R. China
post code 065201
Phone: +86 316 5998198
Fax: +86 316 5759622

info-cn@siegenia.com

France



SIEGENIA GROUP

France sales office
8, rue Jean Monnet
68390 Sausheim
Phone: +33 3 89618131
Fax: +33 3 89619070

info-f@siegenia.com

Poland



SIEGENIA-AUBI Sp. z o.o.

ul. Ossowskiego 64
46-203 Kluczbork
Phone: +48 77 4477700
Fax: +48 77 4477720

info-pl@siegenia.com

Switzerland



SIEGENIA-AUBI AG

Zelgstrasse 97
3661 Uetendorf, Switzerland
Phone: +41 33 3461010
Fax: +41 33 3461020

info-ch@siegenia.com

Great Britain



SIEGENIA-AUBI Ltd.

Richardson Way, Cross Point
Coventry CV2 2TA
Phone: +44 2476 622000
Fax: +44 2476 622364

info-uk@siegenia.com

Russia



SIEGENIA-AUBI OOO

Malaja Semenovskaja Str. 9, Block 14 G
107023 Moscow
Phone: +7 495 7211762
Fax: +7 495 7211130

info-ru@siegenia.com

Turkey



SIEGENIA-AUBI

Yapi Elemanlari San. ve Tic. Ltd. Sti.
Bilmo San. Sitesi, Yanyol Cad, Melodi Sok.
No: 2/22
34956 Tuzla Istanbul
Phone: +90 216 5934151
Fax: +90 216 5934139

info-tr@siegenia.com

Hungary



SIEGENIA-AUBI Kft.

Mártírok útja 4.
H-6000 Kecskemét
Phone: +36 76 500810
Fax: +36 76 500814

info-hu@siegenia.com

South Korea



SIEGENIA Co., Ltd.

76-4, Mokdong, Gwangjushi,
464-020 Gyeonggido
Phone: +82 31 7985590
Fax: +82 31 7985592

info-rok@siegenia.com

Ukraine



SIEGENIA GROUP

Ukraine sales office
Tschernomorskaja Str. 1
04655 Kiew
Phone: +380 44 4637979
Fax: +380 44 4637797

info-ua@siegenia.com

Italy



SIEGENIA-AUBI S.r.l.

Via Varese, 36
20020 Lainate MI
Phone: +39 02 9353601
Fax: +39 02 93799043

info-i@siegenia.com



SIEGENIA GROUP

Hardware and ventilation technology

Industriestraße 1-3

57234 Wilnsdorf

GERMANY

Phone: +49 271 3931-0

Fax: +49 271 3931-333

info@siegenia.com

www.siegenia.com